

dimensions (mm)

A Wheelbase	4800	5100	5400	6000
B Rear overhang	2250	2250	2500	3150
D Overall length	10105	10405	11256	12205
Frame height at rear axle (unladen)	1020	1020	1020	1020
G Back of cab to end of frame	7795	8095	8680	9895
Ground clearance front	287	287	287	287
Ground clearance rear	200	200	200	200
Cab tilt angle	70°	70°	70°	70°
Turning circle (wall to wall) m	20.2	21.1	22.2	24.1
Frame width at rear	757	757	757	757

weights (kg)

Kerb Weights

Wheelbase mm	4800	5100	5400	6000
Front axle	4970	4970	4970	4970
Rear bogie	2905	2945	2985	3065
Total	7875	7915	7955	8035

Plated Weights

	UK Authorised		C&U	Design
Front axle	8000	8000	8000	8000
Drive axle	11500	10500	10500	11500
Trailing axle	7500	6800	6800	7500
GVW	26000	25300	25300	26000
GTW	40000	44000	38000	44000

Weights and dimensions shown are for Long Distance specification with a high roof sleeper cab.

Weights and dimensions are to standard specification with 20 litres of fuel, 5 litres of AdBlue, oil, water and tools.

Kerb weights are subject to a manufacturing tolerance of ±2%. The right is reserved to alter specification or equipment without notice.



engine

Type	2536L	2541L	2544L
		Mercedes-Benz OM501LA 12 litre turbo-intercooled 4 valves per cylinder V6 direct injection diesel	
Max. power @ 1800 rpm	265kW 360PS	300kW 408PS	320kW 435PS
Max. torque @ 1080 rpm	1850Nm 1364lbft	2000Nm 1475lbft	2100Nm 1549lbft
Bore		130mm	
Stroke		150mm	
Capacity		11.95 litres	
Control		Telligent electronic engine management	
Fuel Injection		Direct injection via unit injectors	
Cooling		Water cooled with electromagnetic fan	
Security		Immobiliser to Thatcham H2	
Engine brake		Constant throttle & butterfly	
Exhaust		Stainless steel with SCR catalytic converter	

Performance Curves

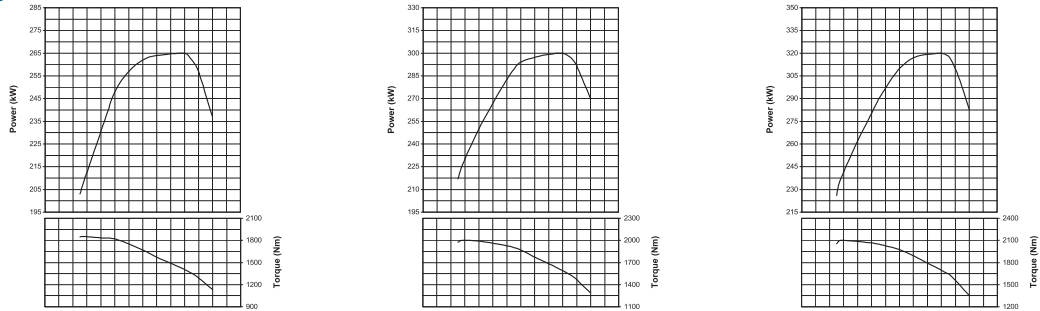

Type	2546L	2548L
	Mercedes-Benz OM501LA 12 litre turbo-intercooled 4 valves per cylinder V6 direct injection diesel	
Max. power @ 1800 rpm	335kW 456PS	350kW 476PS
Max. torque @ 1080 rpm	2200Nm 1623lbft	2300Nm 1696lbft
Bore	130mm	
Stroke	150mm	
Capacity	11.95 litres	
Control	Telligent electronic engine management	
Fuel Injection	Direct injection via unit injectors	
Cooling	Water cooled with electromagnetic fan	
Security	Immobiliser to Thatcham H2	
Engine brake	Constant throttle & butterfly	
Exhaust	Stainless steel with SCR catalytic converter	

Performance Curves

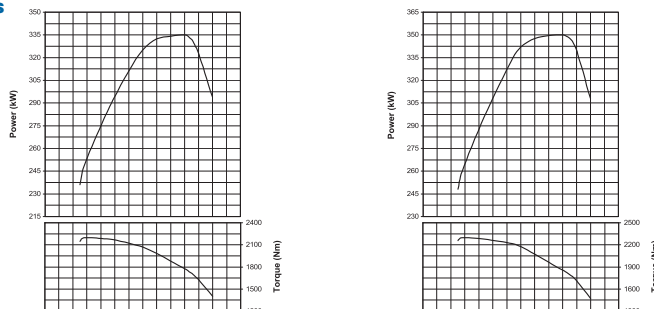



transmission

Gearbox & Gearbox Ratios

Mercedes PowerShift – fully automated 12 speed constant mesh gearbox.

	360, 410, 440		460, 480	
	G211	G281	G211	G281
1st	14.93	14.93	9th	2.05
2nd	11.67	11.64	10th	1.60
3rd	9.93	9.02	11th	1.28
4th	7.06	7.03	12th	1.00
5th	5.63	5.64	1st Reverse	14.93
6th	5.37	4.40	2nd Reverse	11.67
7th	3.39	3.39	3rd Reverse	3.39
8th	2.65	2.65	4th Reverse	2.65

Clutch

Type	Automatically actuated single dry plate clutch
Diameter	430mm

Axles

Front	Mercedes-Benz 'I' beam
Rear Bogie	Mercedes-Benz single reduction Cross-axle differential lock
Trailing	Mercedes-Benz tubular non steered

chassis

Brakes

Front/Rear Service	Disc brakes Telligent electro-pneumatic braking Dual circuit air 10 bar operating pressure Load sensing Automatic brake adjustment Heated air dryer Anti-lock brakes ASR traction control Hill hold feature
Secondary Parking	Front, rear and trailer Front, rear spring brakes Spring brakes on drive and trailing axles
Trailer Exhaust brake	Two line Linked to accelerator with override

Suspension

Front axle	Parabolic leaf springs Double acting shock absorbers Stabiliser
Rear axle	Full air with electronic modulation Double acting shock absorbers Stabiliser
Trailing	Full air with lift facility (single tyres)

Fuel Tank

	Capacity (litres)	Position
Fuel		
Long Dist Distribution	590 aluminium	RHS
AdBlue	400 aluminium	RHS
	95	RHS
	Lockable caps	

Rear Axles Ratios & Performance

Engine	360	410	440	460	480
Axle Ratio	2.533	2.533	2.533	2.533	2.533
Max. geared speed (mph)	87	87	87	87	87
RPM at 90kmph (56mph)	1159	1159	1159	1159	1159
% Rolling gradeability					
26 tonne	46	50	+50	+50	+50
44 tonne	27	29	31	32	34
Axle Ratio	2.846	2.846	2.846	2.846	2.846
Max. geared speed (mph)	77	77	77	77	77
RPM at 90kmph (56mph)	1302	1302	1302	1302	1302
% Rolling gradeability					
26 tonne	+50	+50	+50	+50	+50
44 tonne	30	33	34	36	38
Axle Ratio	3.077	3.077	3.077	3.077	3.077
Max. geared speed (mph)	72	72	72	72	72
RPM at 90kmph (56mph)	1408	1408	1408	1408	1408
% Rolling gradeability					
26 tonne	+50	+50	+50	+50	+50
44 tonne	33	35	37	39	41

Steering

Type	Recirculating ball Variable ratio Integral power assistance Steering column adjustable for height and rake Steering column lock
-------------	---

Wheels & Tyres

Wheels	9.00 x 22.5
Tyres	315 / 80R 22.5

Electrical Systems

Voltage	24 volt Starting and lighting Negative insulated return
Batteries	2 x 12 volt, 165Ah (Distribution) 2 x 12 volt, 220Ah (Long Distance)
Electrical Distribution System	Circuit breaker protection
Alternator	28 volt/80 amp

General

Front underrun protection
Rear underride guard
Reinforced rear crossmember
Trailer brake and electrical connections

options

Description	Weight Adjustments		
	Front	Rear	Total
Driveline			
PTO single outlet heavy duty (slow/med/fast)	+30	0	+30
PTO twin outlet heavy duty (slow/med/fast)	+40	0	+40
PTO single outlet light duty (pump or flange mounting)	+10	0	+10
Speedline wheels 9.00 x 22.5	-30	-65	-95
Alcoa wheels 9.00 x 22.5	-40	-80	-120
12 speed Mercedes PowerShift gearbox (G211)	-55	-5	-60
12 speed Mercedes PowerShift gearbox (G281)	0	0	0
16 speed Mercedes PowerShift gearbox	-5	0	-5
16 speed manual/Telligent gearbox	0	0	0
Chassis			
Front air suspension	+30	0	+30
7.5 tonne front axle	-20	0	-20
9 tonne front axle	+17	0	+17
Brakes			
Aluminium air tanks	-20	-10	-30
Electronics			
165Ah batteries	-15	-10	-25
Cab			
Adjustable roof deflector	+33	0	+33
Cab air suspension	+20	0	+20
MegaSpace cab	+230	0	+230
Distribution Day Cab	-180	0	-180

Component weights are provided as a guide but may vary according to production tolerances

NOTE:

For cab options please see the separate Actros Cab Specification Sheet CV 700