

NEW AxOR-C

BLUETEC 5

8x4 Tipper

3236K

3240K

3243K

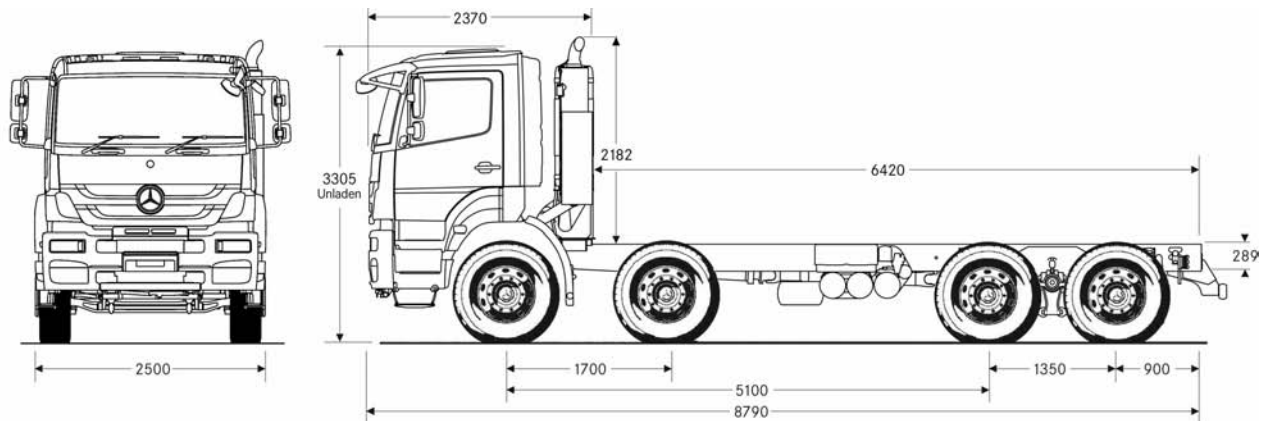

dimensions (mm)

Wheelbase	5100
Frame height at rear (unladen)	1105
Ground clearance front (laden)	319
Ground clearance rear (laden)	257
Cab tilt angle	67°
Turning circle (wall to wall) m	21.5
Width over chassis frame	763

weights (kg)

Kerb Weights

Front bogie	6493
Rear bogie	2922
Total	9415

Plated Weights

	UK Authorised	Design
Front bogie	14200	15000
Rear bogie	19000	19000
GVW	32000	32000
GTW	44000*	44000

*For 44 tonne operation rear bogie must not exceed 17000kg giving a reduced GVW of 31200kg

Weights and dimensions are to standard specification with 20 litres of fuel, 5 litres of AdBlue, oil, water and tools. Kerb weights are subject to a manufacturing tolerance of $\pm 2\%$.

Height dimensions are subject to a manufacturing tolerance of ± 30 mm.

The right is reserved to alter specification or equipment without notice.



Mercedes-Benz
Trucks you can trust

engine

Type	3236K	3240K	3243K
		Mercedes-Benz OM457LA 12 litre turbo-intercooled in-line 6 cylinder direct injection diesel 4 valves per cylinder	
Max. power @1900rpm	265kW 360PS	295kW 401PS	315kW 428PS
Max. torque @1100rpm	1850Nm 1365lbft	2000Nm 1475lbft	2100Nm 1550lbft
Bore		128mm	
Stroke		155mm	
Capacity		11.97 litres	
Control		Telligent electronic engine management	
Fuel Injection		Direct injection via unit injectors	
Cooling		Water cooled with electromagnetic fan	
Security		Immobiliser to Thatcham H2	
Engine Brake		Constant throttle & butterfly	
Exhaust		Stainless steel vertical exhaust with SCR catalytic converter	

Performance Curves

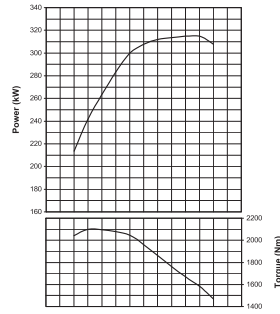
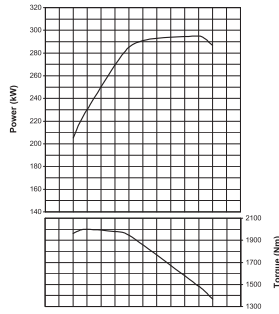
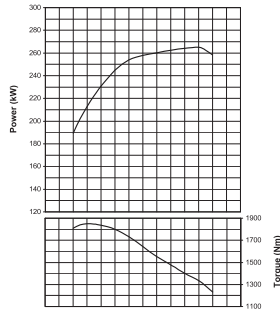

transmission

Gearbox & Ratios

9 speed synchromesh range change. Hydraulic gearshift with 'double H' shift pattern.

Type	G221-9
Crawler	16.15
1st	10.19
2nd	7.16
3rd	5.13
4th	3.38
5th	2.66
6th	1.87
7th	1.34
8th	1.00
Reverse	14.19
PTO	Single outlet MB2c pump mount (4 bolt DIN)

Axles

Front	Mercedes-Benz straight 'I' beam
Rear bogie	Mercedes-Benz single reduction Inter-axle and cross-axle differential locks

chassis

Brakes

Front/Rear	Disc brakes all round, with shields on rear axles
Service	Dual circuit air system Rear axle load sensing Automatic brake adjustment Heated air dryer Anti-lock brakes (ABS)
Parking	Rear spring brake actuators Hand control operation
Engine braking	Activated by 2-stage column stalk Stage 1 constant throttle Stage 2 constant throttle and butterfly

Suspension

Front bogie	Compensating 2-leaf parabolic springs Double acting shock absorbers Stabiliser on 2nd axle
Rear axle	Two spring bogie Double acting shock absorbers Stabilisers

Steering

Type	Variable ratio recirculating ball Integral power assistance Steering column lock Single circuit steering
Adjustable column	Steering column adjustable for height and rake 70mm height, 11° angle, pneumatically locked

Clutch

Type	Hydraulically operated dual dry plate with air assistance
Diameter	395mm

Rear Axle Ratios & Performance

Model	3236K	3240K	3243K
Axle Ratio	3.077	3.077	3.077
Geared Speed (mph)	74	74	74
Engine revs at 56mph	1443	1443	1443
Max. Gradeability % (rolling)			
32 tonne	+50	+50	+50
44 tonne	38	41	43

Alternative axle ratios may be available on request.

Wheels & Tyres

Wheels	8.25 x 22.5
Tyres front	295/80R 22.5
rear	295/80R 22.5

Fuel Tank

Fuel	Capacity (litres)	Position
AdBlue	300 aluminium 40 Lockable caps	RHS RHS

Electrical Systems

Voltage	24 volt Negative insulated return
Batteries	2 x 12 volt, 135Ah
Electrical Distribution System	CAN bus technology Circuit breakers
Alternator	28 volt/80 amp
Body builder electrical interface	PSM
Telligent maintenance system	Standard

General

Plastic front bumper
Headlamp protection grilles

options

Description	Weight Adjustments		
	Front	Rear	Total
Driveline			
16 speed gearbox G210-16	10	0	10
PTOs			
Range of single and twin outlet PTOs	-	-	-
Chassis			
7.5 tonne front axle with 315/80R front tyres	22	0	22
Steel front bumper	20	0	20
Hub reduction rear bogie (only with 16 speed gearbox)	-	155	155
Electrics			
165Ah batteries	10	10	20
200Ah batteries	15	10	25
100 amp alternator	-	-	-
Headlamp washers	5	0	5
Halogen front fog lights	5	0	5
Audible reverse warning	-	-	-
Mixer Pack			
Deletion of gearbox PTO			
Front axle stabiliser			
Non reinforced stabiliser on 4th axle			
Standard rear crossmember			

NOTE:

For cab options please see the separate Axor Cab Specification Sheet CV 715